

Agilent HSDL-3203 Small Profile Package IrDA[®] Data Compliant Low Power 115.2 kbit/s Infrared Transceiver Data Sheet



Description

The HSDL-3203 is a miniature low cost infrared transceiver module that provides the interface between logic and infrared (IR) signals for through air, serial, half-duplex IR data link. The module is compliant to IrDA Physical Layer Specifications version 1.4 Low Power from 9.6 kbit/s to 115.2 kbit/s with extended link distance and it is IEC 825-Class 1 eye safe.

The HSDL-3203 can be shutdown completely to achieve very low power consumption. In the shutdown mode, the PIN diode will be inactive and thus producing very little photocurrent even under very bright ambient light. Such features are ideal for battery operated handheld products.

Applications

- **Mobile telecom**
 - Mobile phones
 - Pagers
 - Smart phone
- **Data communication**
 - PDAs
 - Portable printers
- **Digital imaging**
 - Digital cameras
 - Photo-imaging printers
- **Electronic wallet, IrFM**

Features

- Fully compliant to IrDA 1.4 low power specification from 9.6 kbit/s to 115.2 kbit/s
- Low power operation at extended link distance of 50 cm
- Miniature package
 - Height: 1.95 mm
 - Width: 8.00 mm
 - Depth: 3.10 mm
- Guaranteed temperature performance, -20 to $+70^{\circ}\text{C}$
 - Critical parameters are guaranteed over temperature and supply voltage
- Low power consumption
 - Low shutdown current (10 nA typical)
 - Complete shutdown of TXD, RXD, and PIN diode
- Withstands > 100 mV_{p-p} power supply ripple typically
- V_{CC} supply 2.7 to 3.6 volts
- Integrated EMI shield
- LED stuck-high protection
- Designed to accommodate light loss with cosmetic windows
- IEC 825-Class 1 Eye Safe



Application Support Information

The Application Engineering group in Agilent Technologies is available to assist you with the technical understanding associated with HSDL-3203 infrared transceiver module. You can contact them through your local Agilent sales representative for additional details.

Ordering Information

Part Number	Packaging Type	Package	Quantity
HSDL-3203-021	Tape and Reel	Front View	2500

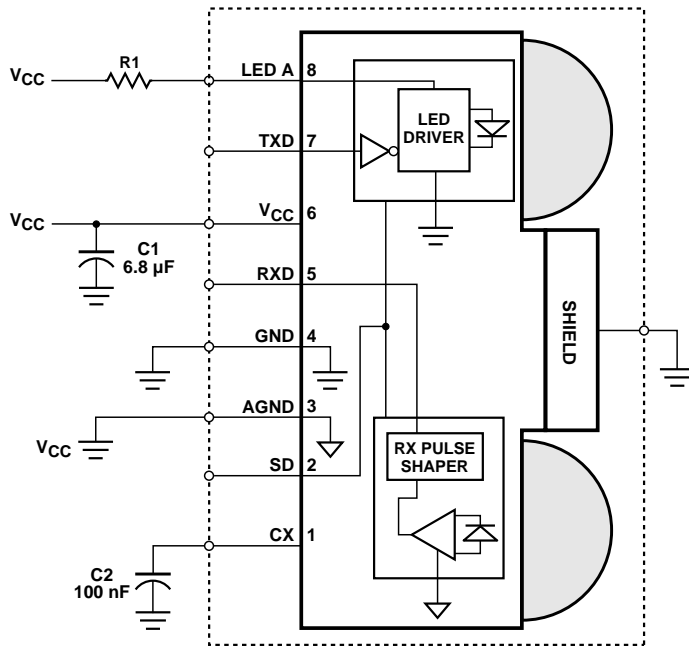

Figure 1. Functional block diagram of HSDL-3203.

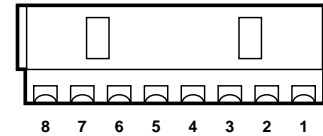

Figure 2. Rear view diagram with pin-out.

I/O Pin Configuration Table

Pin	Symbol	I/O	Description	Note
1	CX	I	Pin bypass capacitor	
2	SD	I	Shutdown. Active high	1
3	AGND	I	Analog ground	2
4	GND	I	Ground	2
5	RXD	O	Receiver data output. Active low	3
6	V _{CC}	I	Supply voltage	4
7	TXD	I	Transmitter data input. Active high	5
8	LED A	I	LED anode	6
–	Shield	–	EMI shield	7

Notes:

1. Complete shutdown TXD, RXD, and PIN diode.
2. Connect to system ground.
3. Output is active low pulse response when light pulse is seen.
4. Regulated, 2.7 to 3.6 volt.
5. Logic high turns on the LED. If held high longer than ~50 μ s, the LED is turned off automatically. TXD must be driven either high or low. DO NOT leave the pin floating.
6. Tied through external resistor, R1, to regulate V_{CC} from 2.7 to 3.6 volt.
7. Connect to system ground via a low inductance trace. For best performance, do not connect to GND directly at the part.

Recommended Application Circuit Components

Component	Recommended Value	Note
R1	30 Ω , \pm 1%, 0.125 Watt	8
R1	5.6 Ω , \pm 1%, 0.125 Watt	9
C1	6.8 μ F, \pm 20%, Tantalum	10
C2	100 nF, \pm 20%, X7R Ceramic	

Notes:

8. To obtain I_{LED} of 50 mA for V_{LED} of 3 V.
9. To obtain I_{LED} of 250 mA for V_{LED} of 3 V.
10. C1 must be placed within 0.7 cm of the HSDL-3203 to obtain optimum noise immunity.

Marking Information

The unit is marked with the letters "A" and the datacode "YWW" on the shield for front options where Y is the last digit of the year, and WW is the workweek.

Transceiver I/O Truth Table

Inputs			Outputs		
TXD	Light Input to Receiver	SD	LED	RXD	Note
High	Don't Care	Low	On	Not Valid	
Low	High	Low	Off	Low	11, 12
Low	Low	Low	Off	High	
Don't Care	Don't Care	High	Off	High	

Notes:

11. In-band IrDA signals and data rates \leq 115.2 kbit/s.
12. RXD logic low is a pulsed response. The condition is maintained for a duration independent of pattern and strength of the incident intensity.

Caution: The BiCMOS inherent to the design of this component increases the component's susceptibility to damage from electrostatic discharge (ESD). It is advised that normal static precautions be taken in handling and assembly of this component to prevent damage and/or degradation, which may be induced by ESD.

Absolute Maximum Ratings

For implementation where case to ambient thermal resistance is $\leq 50^{\circ}\text{C}/\text{W}$.

Parameter	Symbol	Min.	Max.	Units	Conditions
Storage Temperature	T_S	-40	100	$^{\circ}\text{C}$	
Operating Temperature	T_A	-25	85	$^{\circ}\text{C}$	
DC LED Current	$I_{\text{LED}}(\text{DC})$		20	mA	
Peak LED Current	$I_{\text{LED}}(\text{PK})$		250	mA	$\leq 90 \mu\text{s}$ Pulse Width $\leq 25\%$ Duty Cycle
LED Anode Voltage	V_{LEDA}	-0.5	7	V	
Supply Voltage	V_{CC}	0	7	V	
Input Voltage TXD, SD	V_I	0	$V_{\text{CC}} + 0.5$	V	
Output Voltage RXD	V_O	-0.5	$V_{\text{CC}} + 0.5$	V	

Recommended Operating Conditions

Parameter	Symbol	Min.	Max.	Units	Conditions	Note
Operating Temperature	T_A	-25	85	$^{\circ}\text{C}$		
Supply Voltage	V_{CC}	2.7	3.6	V		
Logic High Voltage TXD, SD	V_{IH}	$2/3 V_{\text{CC}}$	V_{CC}	V		
Logic Low Voltage TXD, SD	V_{IL}	0	$1/3 V_{\text{CC}}$	V		
Logic High Receiver Input Irradiance	E_{IH}	0.0081	500	mW/cm^2	For in-band signals	13
Logic Low Receiver Input Irradiance	E_{IL}		0.3	$\mu\text{W}/\text{cm}^2$	For in-band signals	13
LED Current Pulse Amplitude	I_{LEDA}	50	250	mA	Guaranteed at 25°C	
Receiver Signal Rate		9.6	115.2	kbit/s		

Note:

13. An in-band optical signal is a pulse/sequence where the peak wavelength, λ_p , is defined as $850 \text{ nm} \leq \lambda_p \leq 900 \text{ nm}$, and the pulse characteristics are compliant with the IrDA Serial Infrared Physical Layer Link Specification.

Electrical and Optical Specifications

Specifications hold over the recommended operating conditions unless otherwise noted. Unspecified test conditions can be anywhere in their operating range. All typical values are at 25°C and 3.0 V unless otherwise noted.

Parameter		Symbol	Min.	Typ.	Max.	Units	Conditions	Note
Receiver								
RXD Output Voltage	Logic Low	V_{OL}	0		0.4	V	$I_{OL} = 200 \mu\text{A}$, for in-band EI	14
	Logic High	V_{OH}	V_{CC} -0.2		V_{CC}	V	$I_{OH} = 200 \mu\text{A}$, for in-band EI $\leq 0.3 \mu\text{W}/\text{cm}^2$	
Viewing Angle		$2\phi_{1/2}$	30			°		
Logic High Receiver Input Irradiance		E_{IH}	0.0081		500	mW/cm^2	For in-band signals $\leq 115.2 \text{ kbit/s}$	13
Logic Low Receiver Input Irradiance		E_{IL}			0.3	$\mu\text{W}/\text{cm}^2$	For in-band signals	13
Peak Sensitivity Wavelength		λ_p		880		nm		
RXD Pulse Width		tpw	1.5	2.5	4.0	μs		14
RXD Rise and Fall Times		t_r, t_f		25	100	ns	tpw(EI) = 1.6 μs , $C_L = 10 \text{ pF}$	
Receiver Latency Time		t_L		25	50	μs		14
Receiver Wake Up Time		t_W		50	100	μs		15
Transmitter								
Radiant Intensity		E_{IH}	4	8	28.8	mW/sr	$I_{LEDA} = 50 \text{ mA}$, $T_A = 25^\circ\text{C}$, $\theta_{1/2} \leq 15^\circ$	
			22.5			mW/sr	$I_{LEDA} = 250 \text{ mA}$, $T_A = 25^\circ\text{C}$, $\theta_{1/2} \leq 15^\circ$	
Peak Wavelength		λ_p		875		nm		
Spectral Line Half Width		$\Delta\lambda_{1/2}$		35		nm		
Viewing Angle		$2\theta_{1/2}$	30		60	°		
Optical Pulse Width		tpw	1.5	1.6	2	μs	tpw(TXD) = 1.6 μs	
Optical Rise and Fall Times		t_r (EI) t_f (EI)			600	ns	tpw(TXD) = 1.6 μs	
Maximum Optical Pulse Width		tpw (max)		20	50	μs	TXD pin stuck high	
LED Anode ON State Voltage		V_{ON} (LEDA)			1.5	V	$I_{LEDA} = 50 \text{ mA}$, $V_{IH}(\text{TXD}) = 2.7 \text{ V}$	
LED Anode OFF State Leakage		I_{LK} (LEDA)		0.01	1.0	μA	$V_{LEDA} = V_{CC} = 3.6 \text{ V}$, $V_I(\text{TXD}) \leq 1/3 V_{CC}$	
Transceiver								
TXD and SD Input Currents	Logic Low	I_L	-1	-0.01	1	μA	$0 \leq V_I \leq 1/3 V_{CC}$	
	Logic High	I_H		0.01	1	μA	$V_I \geq 2/3 V_{CC}$	
Supply Current	Shutdown	I_{CC1}		10	200	nA	$V_{CC} = 3.6 \text{ V}$, $V_{SD} \geq V_{CC} - 0.5$	
	Idle	I_{CC2}		2.5	4	mA	$V_{CC} = 3.6 \text{ V}$, $V_I(\text{TXD}) \leq 1/3 V_{CC}$, EI = 0	
	Active Receiver	I_{CC3}		2.6	5	mA	$V_{CC} = 3.6 \text{ V}$, $V_I(\text{TXD}) \leq 1/3 V_{CC}$	16

Notes:

14. For in-band signals $\leq 115.2 \text{ kbit/s}$ where $8.1 \mu\text{W}/\text{cm}^2 \leq EI \leq 500 \text{ mW}/\text{cm}^2$.

15. Wake up time is measured from SD pin HIGH to LOW transition or V_{CC} power ON to valid RXD output.

16. Typical value is at EI = 10 mW/cm^2 , maximum value is at EI = 500 mW/cm^2 .

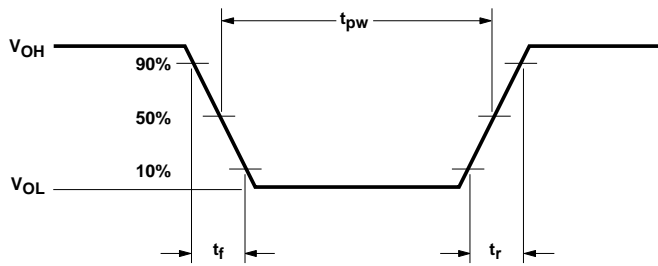

Figure 3. RXD output waveform.

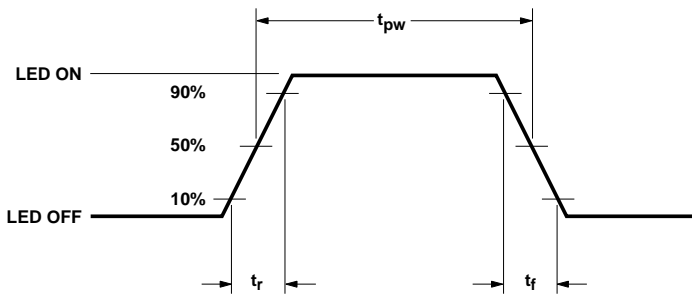

Figure 4. LED optical waveform.

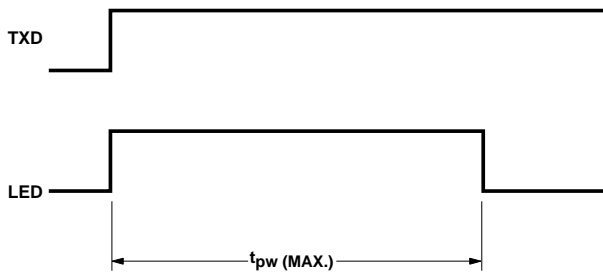

Figure 5. TXD 'Stuck On' protection waveform.

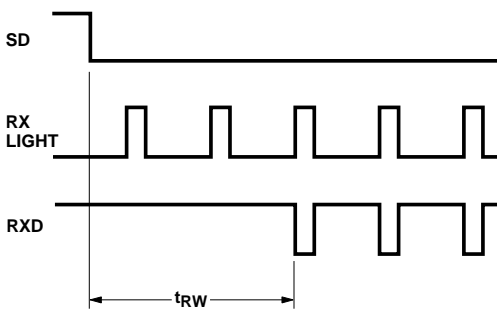

Figure 6. Receiver wakeup time waveform.

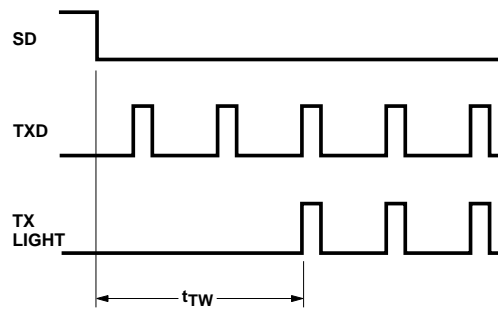

Figure 7. TXD wakeup time waveform.

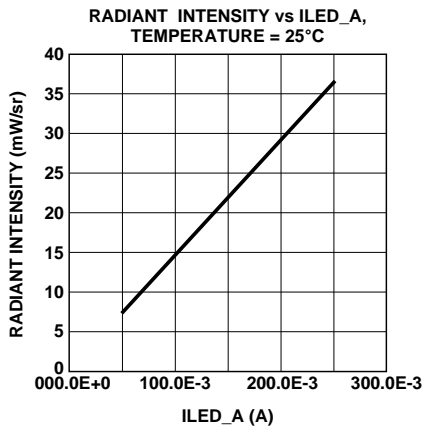

Figure 8. LOP vs. ILED.

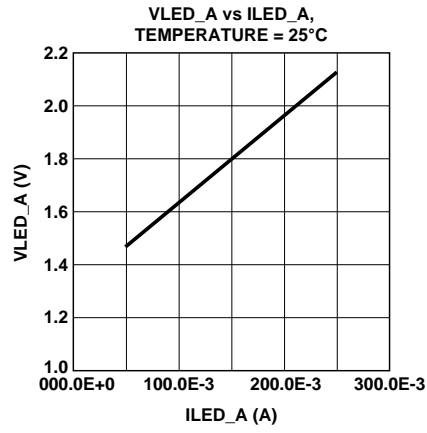

Figure 9. VLED vs. LED current.

Package Outline with Dimensions

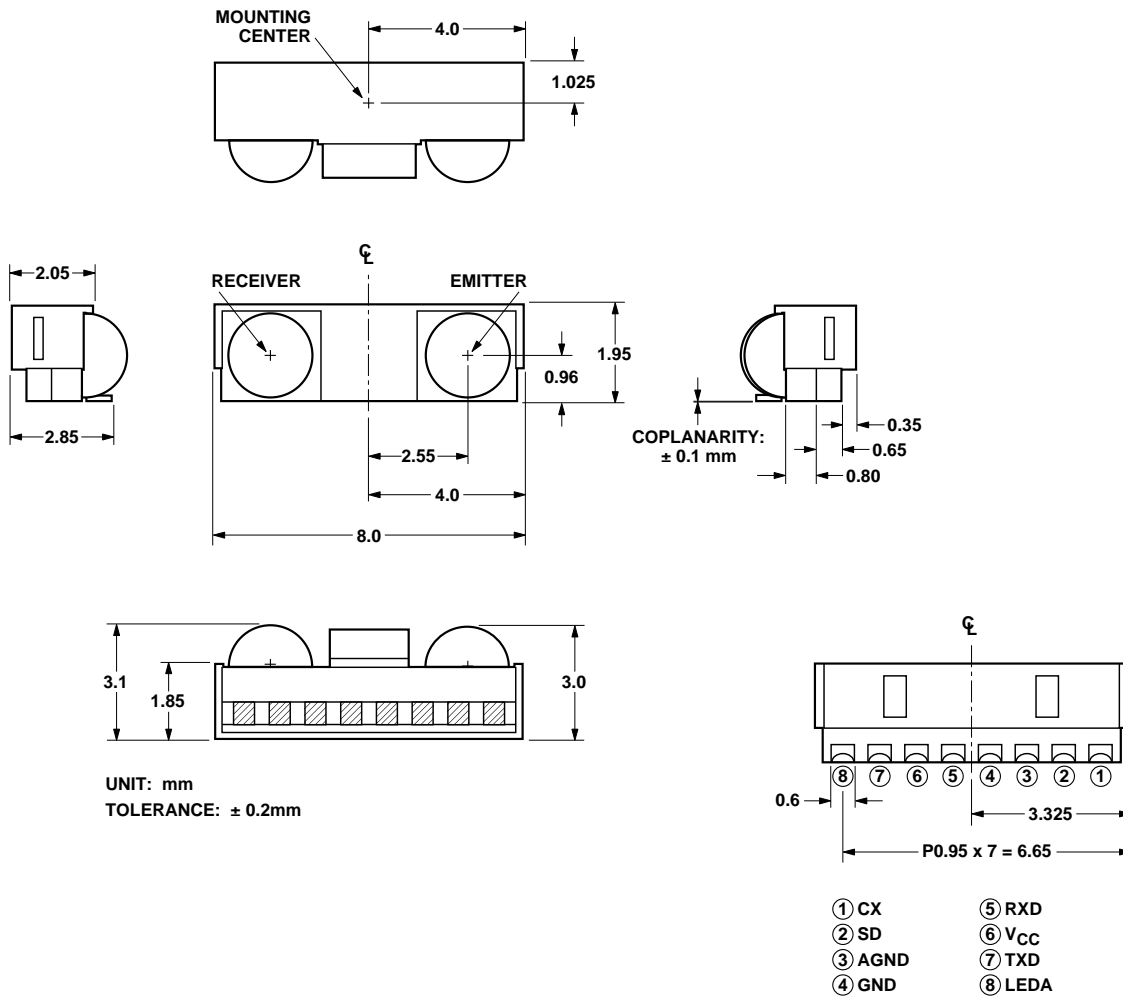

Figure 10. Package outline dimensions.

Tape and Reel Dimensions

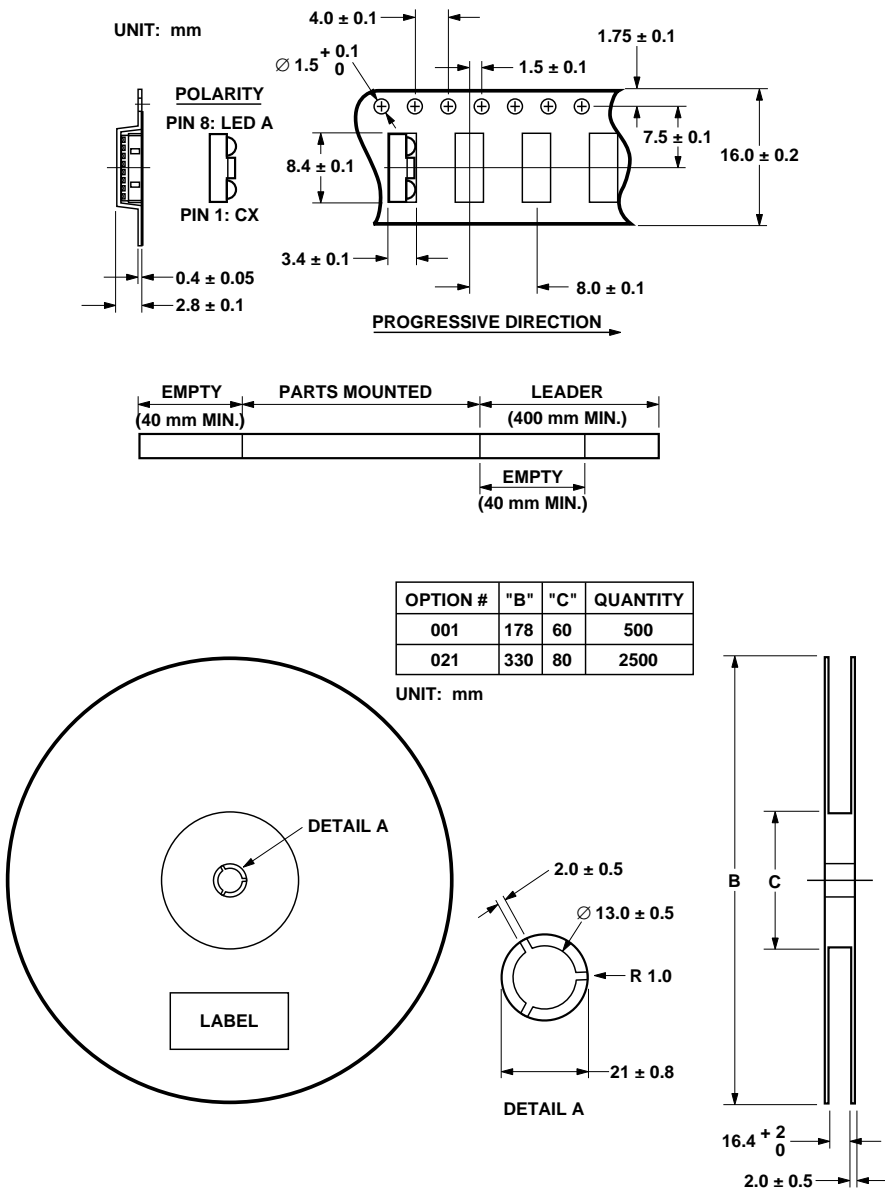

Figure 11. Tape and reel dimensions.

Moisture-Proof Packaging

All HSDL-3203 options are shipped in moisture-proof packaging. Once opened, moisture absorption begins.

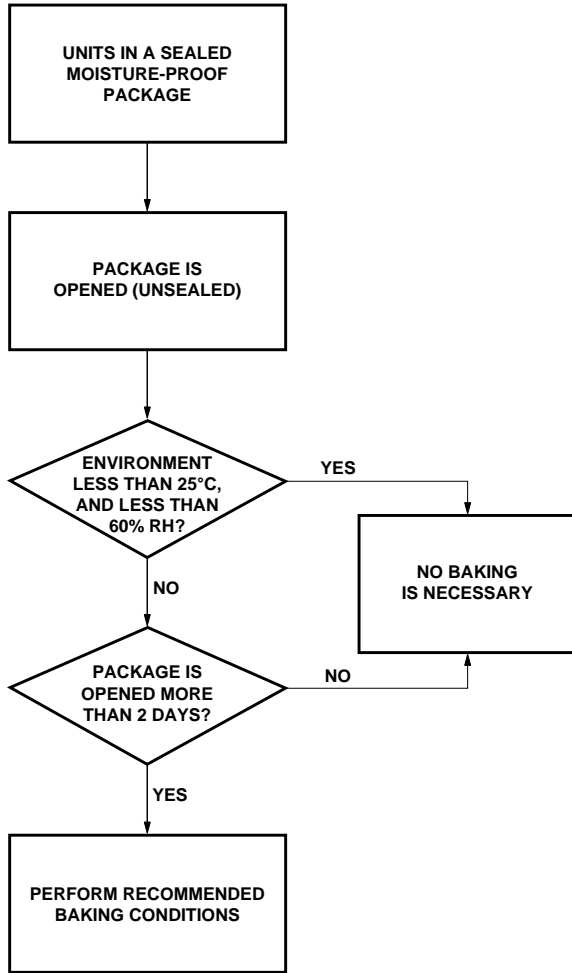

Figure 12. Baking conditions chart.

Baking Conditions

If the parts are not stored in dry conditions, they must be baked before reflow to prevent damage to the parts.

Packaging	Temp.	Time
In Reels	60°C	≥ 48 hours
In Bulk	100°C	≥ 4 hours
	125°C	≥ 2 hours
	150°C	≥ 1 hour

Baking should only be done once.

Recommended Storage Conditions

Storage Temp.	10°C to 30°C
Relative Humidity	Below 60% RH

Time from Unsealing to Soldering

After removal from the bag, the parts should be soldered within two days if stored at the recommended storage conditions. If times longer than two days are needed, the parts must be stored in a dry box.

Reflow Profile

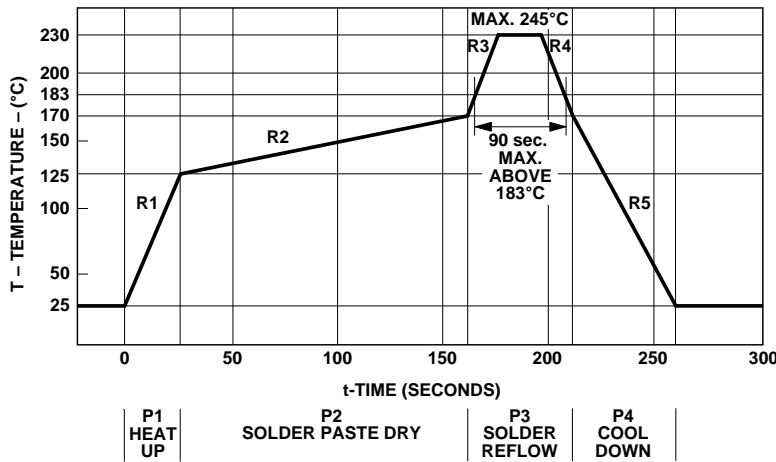

Figure 13. Reflow graph.

Process Zone	Symbol	ΔT	Maximum $\Delta T/\Delta \text{time}$
Heat Up	P1, R1	25°C to 125°C	4°C/s
Solder Paste Dry	P2, R2	125°C to 170°C	0.5°C/s
Solder Reflow	P3, R3	170°C to 230°C (245°C at 10 seconds max.)	4°C/s
	P3, R4	230°C to 170°C	-4°C/s
Cool Down	P4, R5	170°C to 25°C	-3°C/s

The reflow profile is a straight line representation of a nominal temperature profile for a convective reflow solder process. The temperature profile is divided into four process zones, each with different $\Delta T/\Delta \text{time}$ temperature change rates. The $\Delta T/\Delta \text{time}$ rates are detailed in the above table. The temperatures are measured at the component to printed circuit board connections.

In **process zone P1**, the PC board and HSDL-3203 castellation I/O pins are heated to a temperature of 125°C to activate the flux in the solder paste. The temperature ramp up rate, R1, is limited to 4°C per second to allow for even heating of both the PC board and HSDL-3203 castellation I/O pins.

Process zone P2 should be of sufficient time duration (> 60 seconds) to dry the solder paste. The temperature is raised to a level just below the liquidus point of the solder, usually 170°C (338°F).

Process zone P3 is the solder reflow zone. In zone P3, the temperature is quickly raised above the liquidus point of solder to 230°C (446°F) for optimum results. The dwell time above the liquidus point of solder should be between 15 and 90 seconds. It usually takes about 15 seconds to assure proper coalescing of the solder balls into liquid solder and the formation of good solder connections. Beyond a dwell time of 90 seconds, the inter-

metallic growth within the solder connections becomes excessive, resulting in the formation of weak and unreliable connections. The temperature is then rapidly reduced to a point below the solidus temperature of the solder, usually 170°C (338°F), to allow the solder within the connections to freeze solid.

Process zone P4 is the cool down after solder freeze. The cool down rate, R5, from the liquidus point of the solder to 25°C (77°F) should not exceed -3°C per second maximum. This limitation is necessary to allow the PC board and HSDL-3203 castellation I/O pins to change dimensions evenly, putting minimal stresses on the HSDL-3203 transceiver.

Appendix A : SMT Assembly Application Note

1.0 Solder Pad, Mask and Metal Solder Stencil Aperture

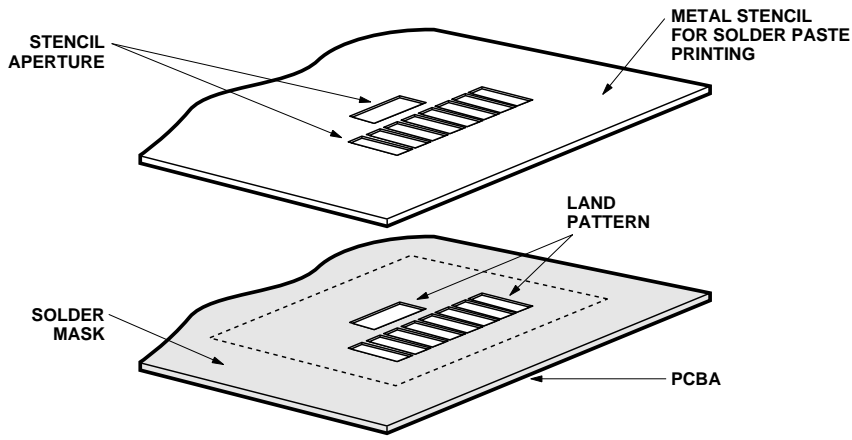

Figure 14. Stencil and PCBA.

1.1 Recommended Land Pattern

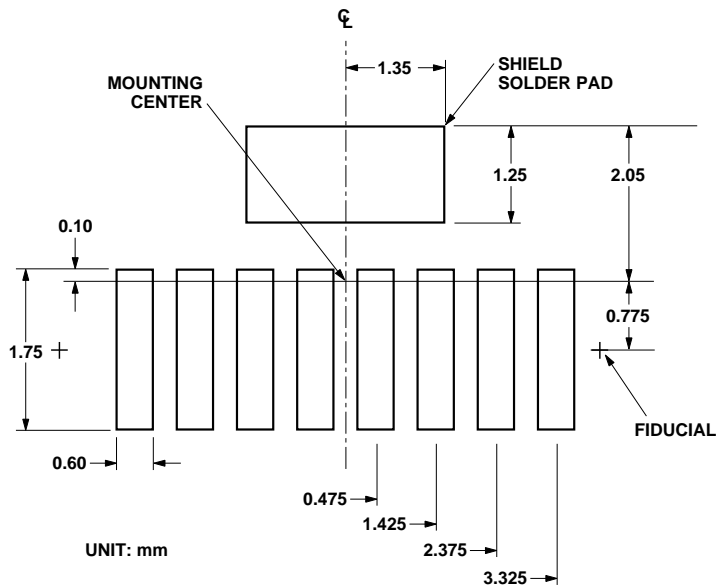

Figure 15. Land pattern.

1.2 Recommended Metal Solder Stencil Aperture

It is recommended that only a 0.152 mm (0.006 inches) or a 0.127 mm (0.005 inches) thick stencil be used for solder paste printing. This is to ensure adequate printed solder paste volume and no shorting. See the table below the drawing for combinations of metal stencil aperture and metal stencil thickness that should be used.

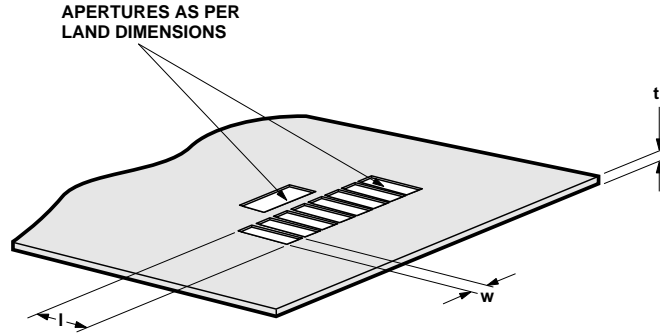

Figure 16. Solder stencil aperture.

Aperture opening for shield pad is 2.7 mm x 1.25 mm as per land pattern.

Stencil Thickness, <i>t</i> (mm)	Aperture Size (mm)	
	Length, <i>l</i>	Width, <i>w</i>
0.152 mm	2.60 ± 0.05	0.55 ± 0.05
0.127 mm	3.00 ± 0.05	0.55 ± 0.05

1.3 Adjacent Land Keepout and Solder Mask Areas

Adjacent land keep-out is the **maximum space** occupied by the unit relative to the land pattern. There should be no other SMD components within this area.

The minimum solder resist strip width required to avoid solder bridging adjacent pads is **0.2 mm**. It is recommended that two fiducial crosses be placed at mid-length of the pads for unit alignment.

Note: Wet/Liquid Photo-Imageable solder resist/mask is recommended.

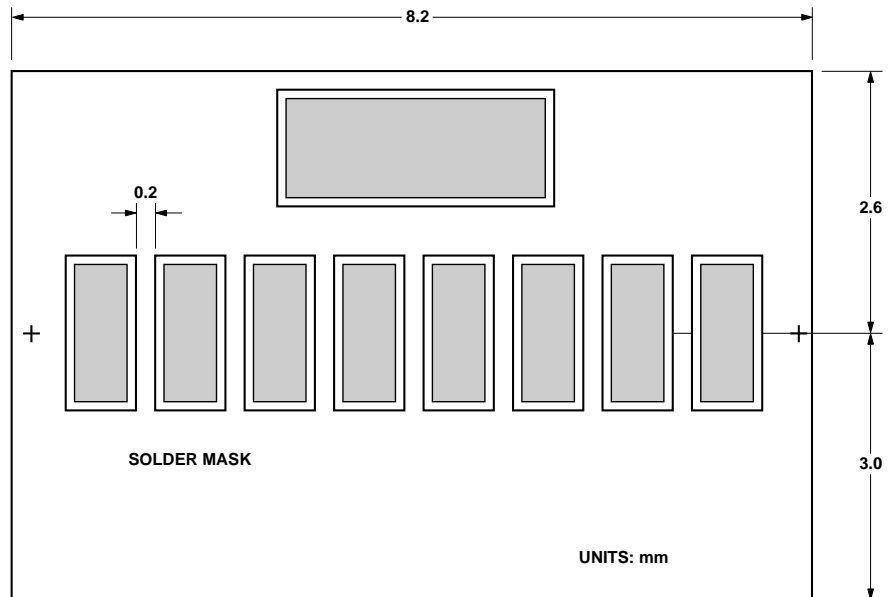

Figure 17. Adjacent land keep-out and solder mask areas.

Appendix B: PCB Layout Suggestion

The following shows an example of a PCB layout using option #021 that would result in good electrical and EMI performance. Things to note:

1. The ground plane should be continuous under the part, but should not extend under the shield trace.
2. The shield trace is a wide, low inductance trace back to the system ground.
3. The AGND pin is connected to the ground plane and not to the shield tab.
4. C1 and C3 are optional supply filter capacitors; they may be left out if a clean power supply is used.
5. VLED can be connected to either unfiltered or unregulated power supply. If VLED and V_{CC} share the same power supply and C1 is used, the connection should be before the C1 cap. In a noisy environment, supply rejection can be enhanced by including C3 as well.

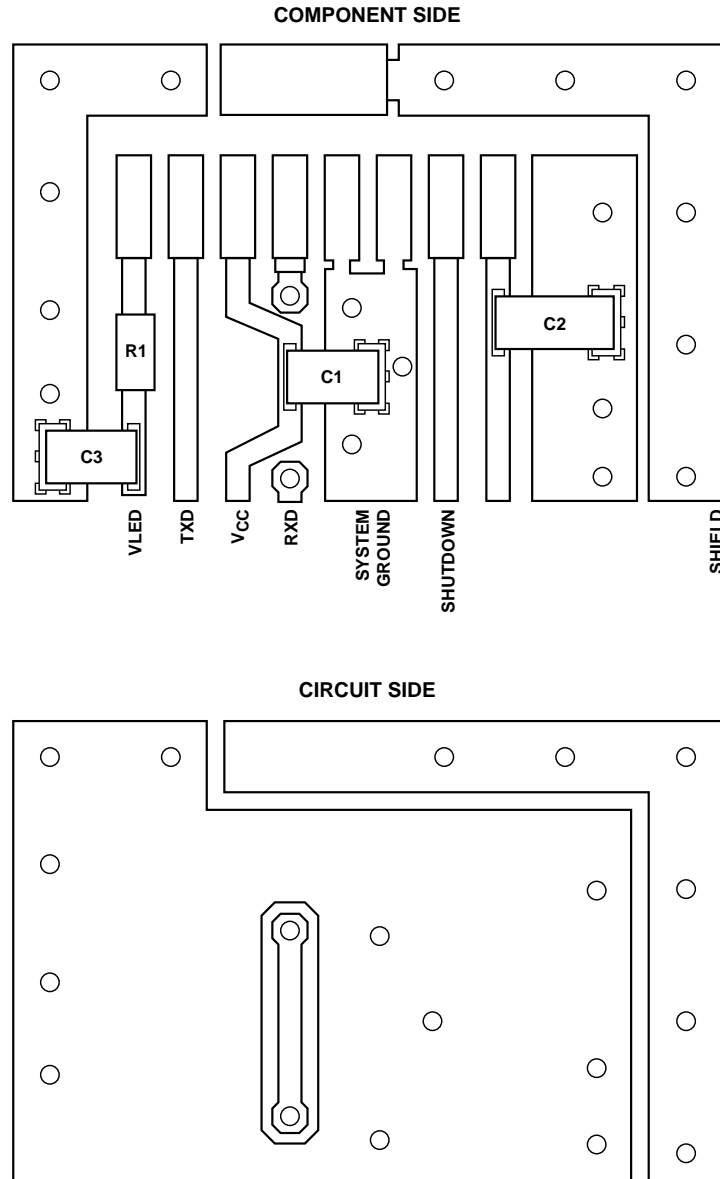

Figure 18. PCB layout suggestions.

Appendix C: General Application Guide for the HSDL-3203 Infrared IrDA® Compliant 115.2 kb/s Transceiver

Description

The HSDL-3203, a wide voltage operating range infrared transceiver, is a low-cost and small form factor device that is designed to address the mobile computing market such as PDAs, as well as small embedded mobile products such as digital cameras and cellular phones. It is fully compliant to IrDA 1.4 low power specification from 9.6 kb/s to 115.2 kb/s, and supports HP-SIR and TV Remote modes. The design of the HSDL-3203 also includes the following unique features:

- Low passive component count.
- Shutdown mode for low power consumption requirement.

Selection of Resistor R1

Resistor R1 should be selected to provide the appropriate peak pulse LED current over different ranges of V_{CC} as shown in the table below.

Recommended R1	V _{CC}	Intensity	Minimum peak pulse LED current
30 Ω	3 V	8 mW/sr	50 mA
5.6 Ω	3 V	34 mW/sr	250 mA

Interface to Recommended I/O Chips

The HSDL-3203's TXD data input is buffered to allow for CMOS drive levels. No peaking circuit or capacitor is required.

Data rate from 9.6 kb/s up to 115.2 kb/s is available at the RXD pin.

The block diagram below shows how the IR port fits into a mobile phone and PDA platform.

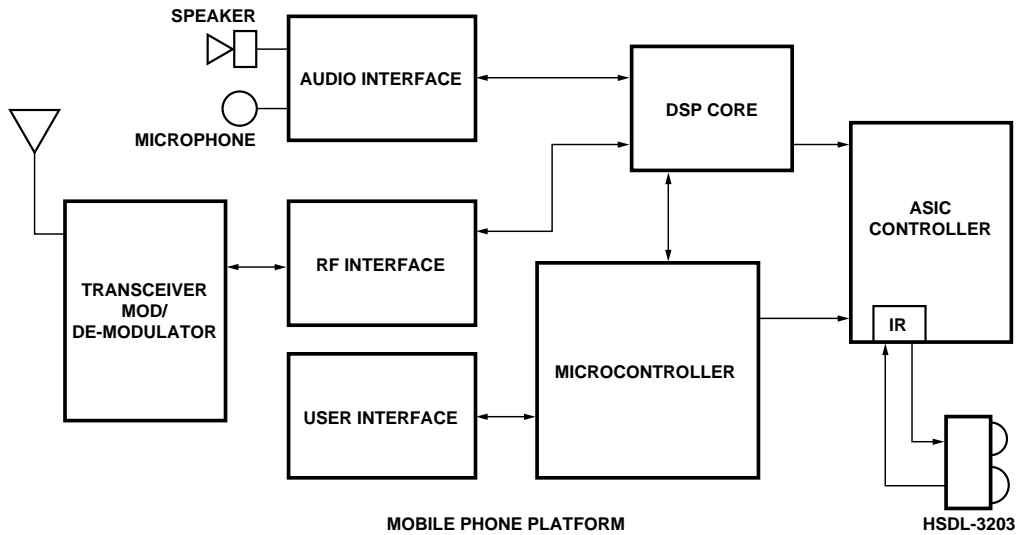

Figure 19. IR layout in mobile phone platform.

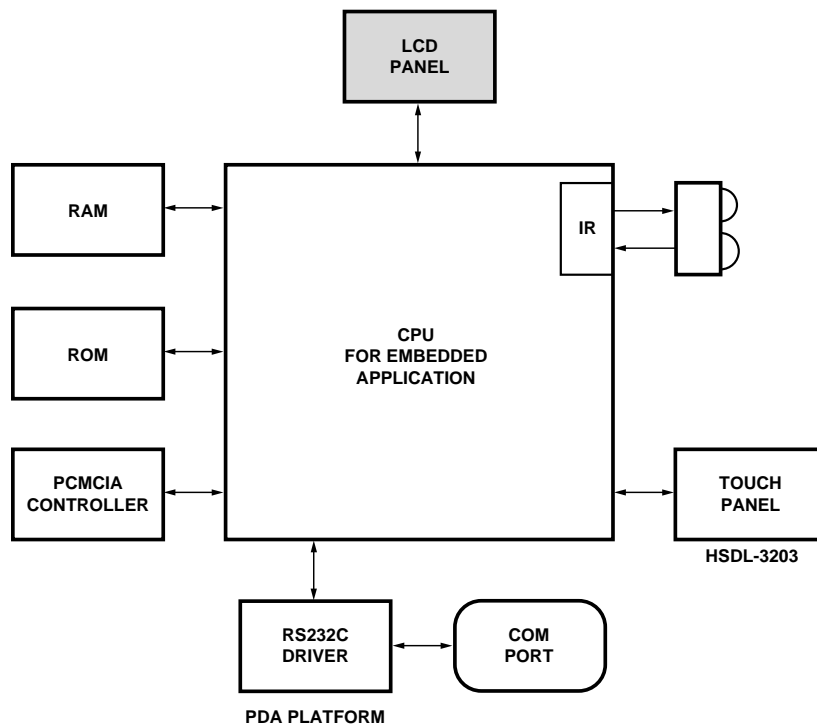

Figure 20. IR layout in PDA platform.

The link distance testing was done using typical HSDL-3203 units with National Semiconductor's PC87109 3V Super I/O controller and SMC's FDC37C669 and FDC37N769 Super I/O controllers. An IR link distance of up to 100 cm was demonstrated.

Appendix D: Optical port dimensions for HSDL-3203:

To ensure IrDA compliance, some constraints on the height and width of the window exist. The minimum dimensions ensure that the IrDA cone angles are met without vignetting. The maximum dimensions minimize the effects of stray light. The minimum size corresponds to a cone angle of 30° and the maximum size corresponds to a cone angle of 60°.

In the figure below, X is the width of the window, Y is the height of the window, and Z is the distance

from the HSDL-3203 to the back of the window. The distance from the center of the LED lens to the center of the photodiode lens, K, is 5.1 mm. The equations for computing the window dimensions are as follows:

$$X = K + 2*(Z + D)*\tan A$$

$$Y = 2*(Z + D)*\tan A$$

The above equations assume that the thickness of the window is negligible compared to the distance of the module from the back of the window (Z). If they are comparable, Z' replaces Z in

the above equation. Z' is defined as:

$$Z' = Z + t/n$$

where 't' is the thickness of the window and 'n' is the refractive index of the window material.

The depth of the LED image inside the HSDL-3203, D, is 3.17 mm. 'A' is the required half angle for viewing. For IrDA compliance, the minimum is 15° and the maximum is 30°. Assuming the thickness of the window to be negligible, the equations result in the following tables and graphs.

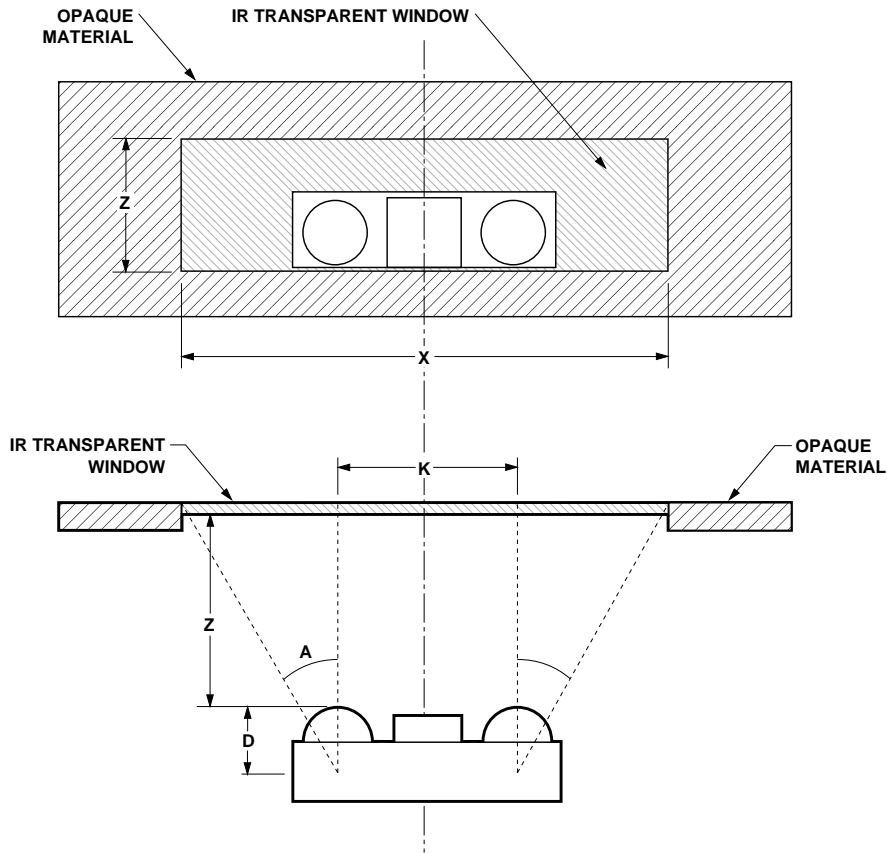

Module Depth (z) mm	Aperture Width (x, mm)		Aperture Height (y, mm)	
	Max.	Min.	Max.	Min.
0	8.76	6.80	3.66	1.70
1	9.92	7.33	4.82	2.33
2	11.07	7.87	5.97	2.77
3	12.22	8.41	7.12	3.31
4	13.38	8.94	8.28	3.84
5	14.53	9.48	9.43	4.38
6	15.69	10.01	10.59	4.91
7	16.84	10.55	11.74	5.45
8	18.00	11.09	12.90	5.99
9	19.15	11.62	14.05	6.52

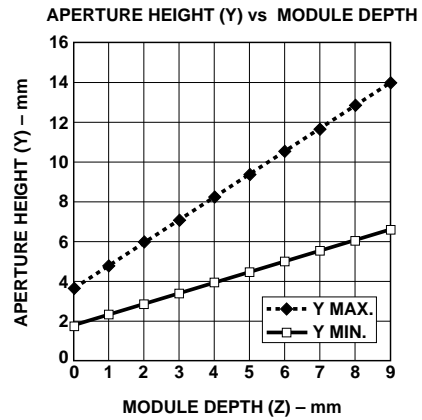
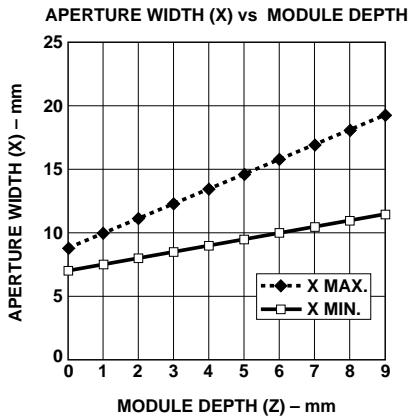

Window Material

Almost any plastic material will work as a window material. Polycarbonate is recommended. The surface finish of the plastic should be smooth, without any texture. An IR filter dye may be used in the window to make it look black to the eye, but the total optical loss of the window should be 10% or less for best optical performance. Light loss should be measured at 875 nm.

The recommended plastic materials for use as a cosmetic window are available from General Electric Plastics. Recommended Plastic Materials:

Material Number	Light Transmission	Haze	Refractive Index
Lexan 141L	88%	1%	1.586
Lexan 920A	85%	1%	1.586
Lexan 940A	85%	1%	1.586

Note: 920A and 940A are more flame retardant than 141L. Recommended Dye: Violet #21051 (IR transmissant above 625 nm).

Shape of the Window

From an optics standpoint, the window should be flat. This ensures that the window will not alter either the radiation pattern of the LED, or the receive pattern of the photodiode.

If the window must be curved for mechanical or industrial design reasons, place the same curve on the back side of the window that has an identical radius as the front side. While this will not completely eliminate the lens effect of the front curved surface, it will significantly reduce the effects. The amount of change in

the radiation pattern is dependent upon the material chosen for the window, the radius of the front and back curves, and the distance from the back surface to the transceiver. Once these items are known, a lens design can be made which will eliminate the effect of the front surface curve.

The following drawings show the effects of a curved window on the radiation pattern. In all cases, the center thickness of the window is 1.5 mm, the window is made of polycarbonate plastic, and the distance from the transceiver to the back surface of the window is 3 mm.

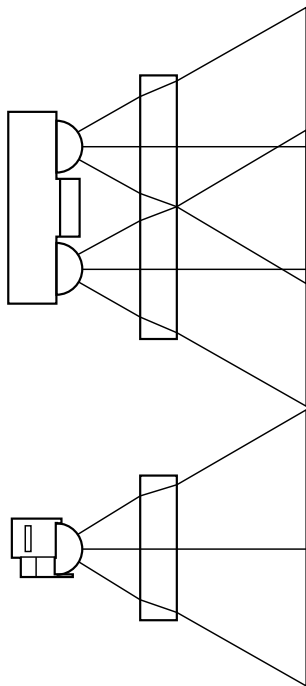

**Flat Window
(First Choice)**

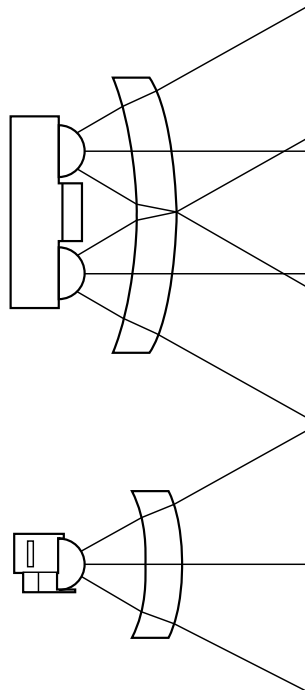

**Curved Front and Back
(Second Choice)**

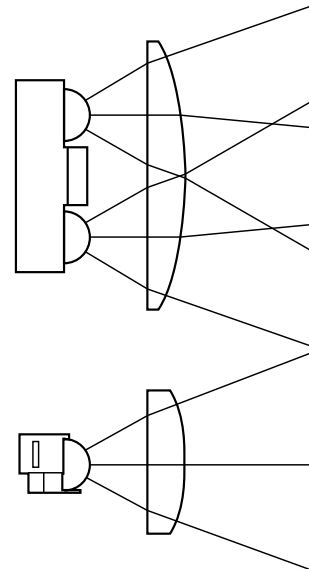

**Curved Front, Flat Back
(Do Not Use)**

www.agilent.com/semiconductors

For product information and a complete list of distributors, please go to our web site.

For technical assistance call:

Americas/Canada: +1 (800) 235-0312 or
(408) 654-8675

Europe: +49 (0) 6441 92460

China: 10800 650 0017

Hong Kong: (+65) 6271 2451

India, Australia, New Zealand: (+65) 6271 2394

Japan: (+81 3) 3335-8152(Domestic/International), or 0120-61-1280(Domestic Only)

Korea: (+65) 6271 2194

Malaysia, Singapore: (+65) 6271 2054

Taiwan: (+65) 6271 2654

Data subject to change.

Copyright © 2002 Agilent Technologies, Inc.

Obsoletes 5988-8122EN

December 20, 2002

5988-8581EN



Agilent Technologies